

I. Calculate the following, using any special instructions given.

(16)

1. w_y if $w = \tan^{-1}\left(\frac{x}{y}\right)$.

2. $\frac{\partial T}{\partial T_2}$ if $\frac{1}{T^4} = \frac{1}{T_1^2} + \frac{1}{T_2^2} + \frac{1}{T_3^2}$, using implicit differentiation.

3. $\frac{\partial z}{\partial \theta}$ if $z = x^3y^2$, where θ is the polar coordinate. Use the Chain Rule, and express the answer in terms of x and y .

4. $f_{yyyyyxyyyyyxyyyyy}(x, y)$ if $f(x, y) = x \tan^3(y^4)$.

II. Verify that $\lim_{(x,y) \rightarrow (0,0)} \frac{x^4}{x^2 + y^2} = 0$ as follows. Writing $f(x, y) = \frac{x^4}{x^2 + y^2}$, check that $f(0, y) = 0$, then
(4) for $x \neq 0$ make an estimate of $\left| \frac{x^4}{x^2 + y^2} \right|$ that shows that when (x, y) is close to the origin, the value of $\left| \frac{x^4}{x^2 + y^2} \right|$ is close to 0. What does the estimate say about the values of $\frac{x^4}{x^2 + y^2}$ on the disc with center at the origin and radius $\frac{1}{100}$?

III. Verify that $\lim_{(x,y) \rightarrow (0,0)} \frac{x^4}{x^2 + y^2} = 0$ as follows. Express $\frac{x^4}{x^2 + y^2}$ in polar coordinates, simplify the resulting
(3) expression, and observe that when (x, y) is close to the origin (that is, when r is close to 0), the value of the expression is close to 0.

IV. In an xy -plane, sketch the domain of the function $f(x, y) = \sqrt{x+y} \ln(y-x)$. Be sure to indicate which
(4) points of the boundary of the region are in the domain (by making them solid lines) and which are not (by making them dotted lines).

V. Use the gradient to find the directional derivative of $f(x, y) = x^2y^3$ at the point $(3, 1)$ in the direction toward the origin.

VI. Let $V = \pi r^2 h$. Calculate dV . Use it to estimate the amount of metal in a can which is 5 inches tall and 2 inches in diameter, if the thickness of the metal is 0.01 in.

VII. Calculate $\frac{\partial}{\partial x} \int_0^{xy} e^{-t^2} dt$.

VIII. The figure to the right shows level curves for a function $f(x, y)$. The value of f on the smallest arc is 1, then on the next larger arc is 2, and so on. Sketch gradient vectors for f , showing enough of them to indicate the general behavior of ∇f .

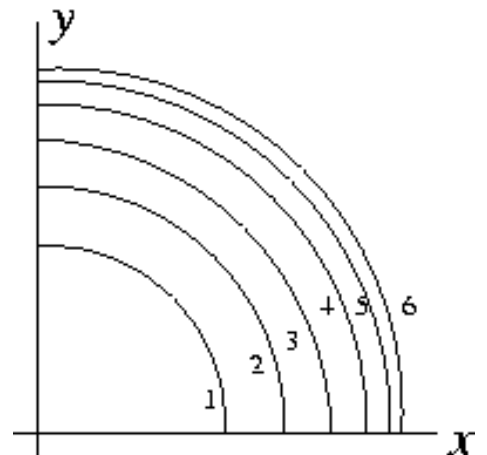

IX. Use the gradient to find an equation for the tangent plane to $x^2 + y^2 + z^2 = 1$ at the point $\left(\frac{1}{\sqrt{2}}, \frac{1}{2}, \frac{1}{2}\right)$.
(5)

X. Write out the Chain Rule for $\frac{\partial \text{silver}}{\partial \text{bronze}}$ if $\text{silver} = \text{silver}(\text{green}, \text{blue}, \text{red})$, where $\text{green} = \text{green}(\text{gold}, \text{bronze})$,
(3) $\text{blue} = \text{blue}(\text{gold}, \text{bronze})$, $\text{red} = \text{red}(\text{gold}, \text{bronze})$.

XI. The figure to the right shows level curves for a function $f(x, y)$,
(3) and a certain point P . The value of f on the smallest arc is 6, then on the next larger arc is 5, and so on. Based on the most straightforward expected behavior of f consistent with these level curves, tell whether each of the following appears to be positive or negative at P .

1. $\frac{\partial f}{\partial x}$
2. $\frac{\partial^2 f}{\partial y^2}$
3. $\frac{\partial^2 f}{\partial y \partial x}$

